











IR Series Paint Curing Equipment

	
With fan in cassette	Reflector A
	
Reflector B	Reflector C
	
Gold-coated reflector	Can go either side of the wheel
	
4" caster with brake	Self-balance arms
	
High strength column	With Filter

Baking area



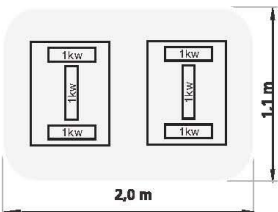
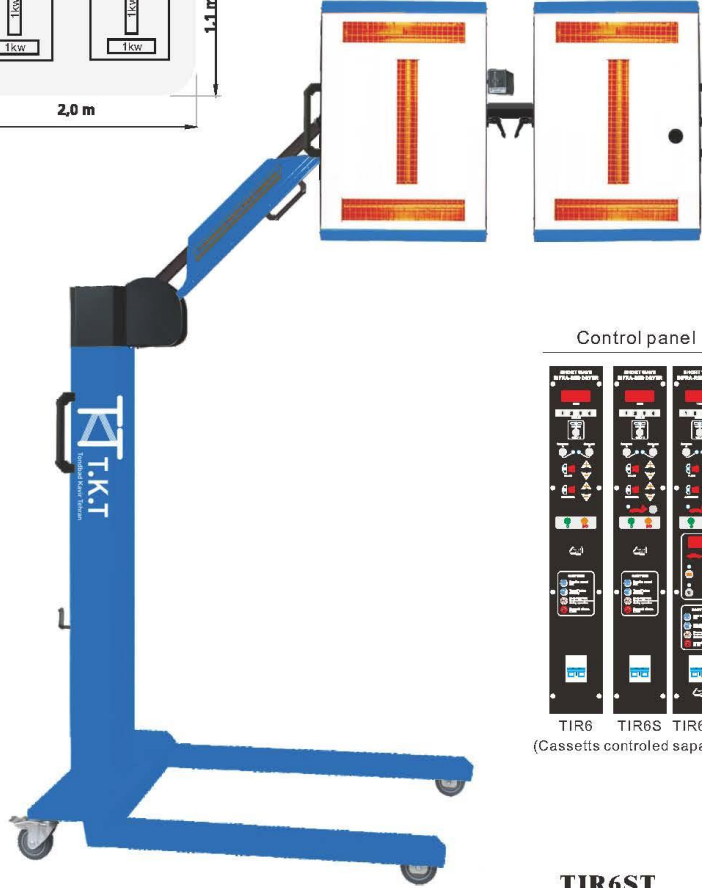

Control panel

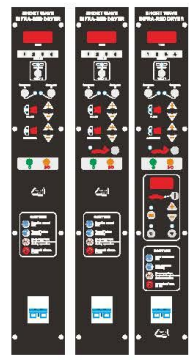

TIR6 TIR6S TIR6ST
(Cassetts controlled saporable)

TIR6ST

TIR6	🕒 📡 🔊 M	Functions: pre-heat and full baking
TIR6S	🕒 📡 🔊 M 🚗	Functions plus equipped with ultrasonic distance sensor
TIR6ST	🕒 📡 🔊 M 🚗 🌡️	Functions plus equipped with ultrasonic distance sensor and temperature controller

Model	🔌	Emitter power (W)	Max power (kVA)	Timing range (min)	Baking area (m ²)	Temperature (°C)	Length of power cord	↕ m	👤 kg
TIR6	400V 3Ph	6000	6.05	2x35	2.0x1.1	60-70	3m	1.2x2.2x 2.43	66.5
TIR6S	400V 3Ph	6000	6.05	2x35	2.0x1.1	60-70	3m	1.2x2.2x 2.43	67
TIR6ST	400V 3Ph	6000	6.05	2x35	2.0x1.1	60-70	3m	1.2x2.2x 2.43	67